



HF Receivers, Part 1

Basic receiver concepts & types

Adam Farson

VA7OJ

[View an excellent tutorial on receivers](#)

Basic Receiver Requirements



- . - . - - . - - . . . - . - - . . . - - . - .
- Amplify the received low-power RF signal.
 - Reject interference and noise which falls outside bandwidth of desired signal.
 - Detect intelligence carried on RF signal (“carrier”); extract intelligence (audio).
 - Amplify audio.

Fundamental Receiver Concepts



- **Sensitivity:** Minimum RF input for usable S/N (signal-to-noise) ratio (usually 10 dB) at audio output.
- **Selectivity:** Receiver's ability to pass desired signal and reject unwanted signals.
- **Noise Figure:** A measure of “noise floor” or weakest detectable signal. Internal noise generated in 1st stage is limiting factor.
- **Minimum Discernible Signal (MDS):** Input level which yields 3 dB S/N at output.
- **Dynamic Range:** Input level range (in dB) between MDS and point at which 1 dB increase in input yields no increase in output.

Basic Receiver Functions



- ◆ **Tuning:** set receiver to specific frequency.
- ◆ **Selectivity:** select desired signal, suppress unwanted signals.
- ◆ **Amplification:** amplify weak signals at antenna input to a useful level.
- ◆ **Demodulation:** convert modulated or keyed RF carrier into audio.

Basic Receiver Types



- **Simple Receivers**
 - ◆ “Crystal Set”
 - ◆ Regenerative Receiver
 - ◆ Superregenerative Receiver

- **Multistage Receivers**
 - ◆ Tuned Radio Frequency (TRF)
 - ◆ Superheterodyne (Superhet)

The “Crystal Set”

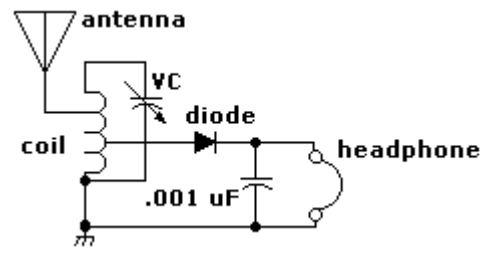

- **Tuning:** rotate VC (variable capacitor) to “tune in” station.
- **Selectivity:** Parallel-tuned circuit (coil + VC). High Z at resonance (passes desired frequency) ; low Z off-resonance attenuates other frequencies.
- **Amplification:** none. Sensitivity adequate for local stations.
- **Demodulation:** diode rectifies AM envelope, .001 μ F capacitor removes RF component. Audio component drives headphone.

The Regenerative Receiver

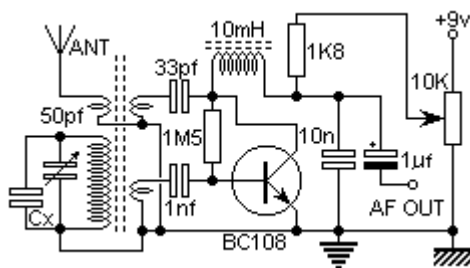

- **Tuning:** rotate variable capacitor.
- **Selectivity:** LC circuit at left, as in crystal set. Coupling windings preserve high Q (= high selectivity).
- **Amplification:** Regeneration creates gain.
- **Demodulation:** Positive feedback (regeneration) in demodulator is set just below onset of self-oscillation, yielding gain. LC low-pass filter in collector circuit strips RF component from audio output.

The Superregenerative Receiver

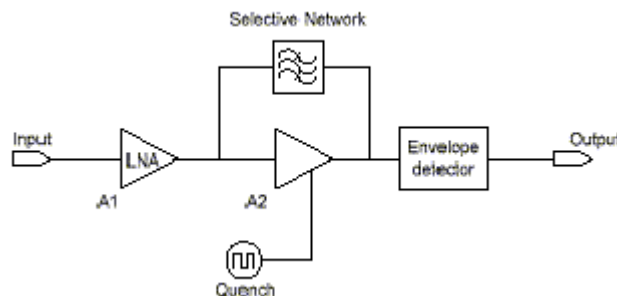

- **Tuning:** vary resonant frequency of tuned circuits in A1 and in selective network (e.g. LC circuit)
- **Selectivity:** Tuned circuits in RF amp. A1, and selective feedback network around regenerative amp. A2.
- **Amplification:** In A1. Also via quenched oscillation in A2, which with its selective feedback forms an oscillator. Square-wave quench signal (approx. 20 kHz) breaks off (quenches) oscillation at quench rate, but positive feedback yields gain.
- **Demodulation:** Envelope detector rectifies A2 output, suppresses RF and quench signal components, and recovers audio.

The TRF (Tuned RF) Receiver

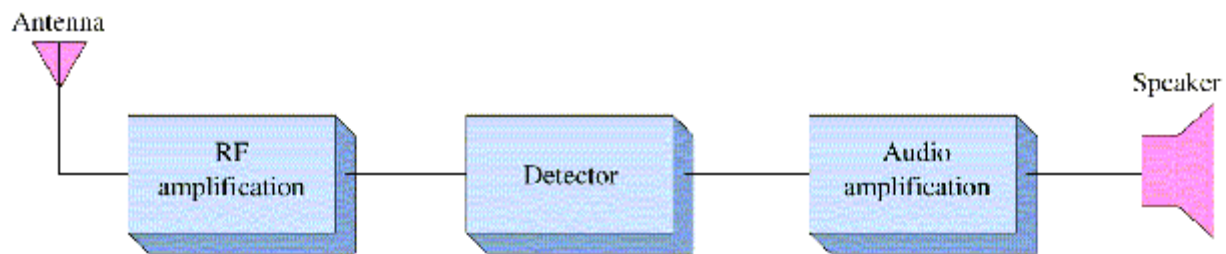

Amplifier to increase sensitivity.

Tuned circuit to receive correct radio signal.

The TRF (Tuned RF) Receiver



- **Tuning & Selectivity:** Tuned circuits at RF amp. input, output.
- **Amplification:** RF amplifier, detector (optional), audio amplifier.
- **Demodulation:** Detector (passive or regenerative).
- **Advantages** over simple receivers:
 - ◆ RF amp. prevents re-radiation from regenerative detector.
 - ◆ Double-tuned RF amp. Improves selectivity.
 - ◆ Cascaded tuned RF amps. yield even tighter selectivity.
- *Early WW2 military communications agencies favoured TRF over superhet (no local-oscillator radiation).*

The Superheterodyne Receiver

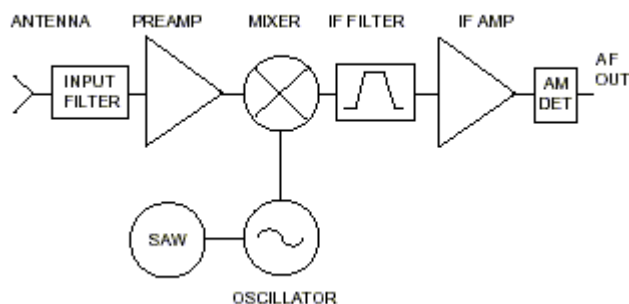

- Invented by Edwin Armstrong (1920's).
- Used universally since WW2.
- Inability to build narrow, tunable RF filters at higher frequencies led to conversion of RF signal to a fixed intermediate frequency (IF).
- Narrow filters feasible at fixed, low IF.
- Mixer is a nonlinear device: “mixes” RF signal with local oscillator to produce IF.

The Superheterodyne Receiver: frequency relationships

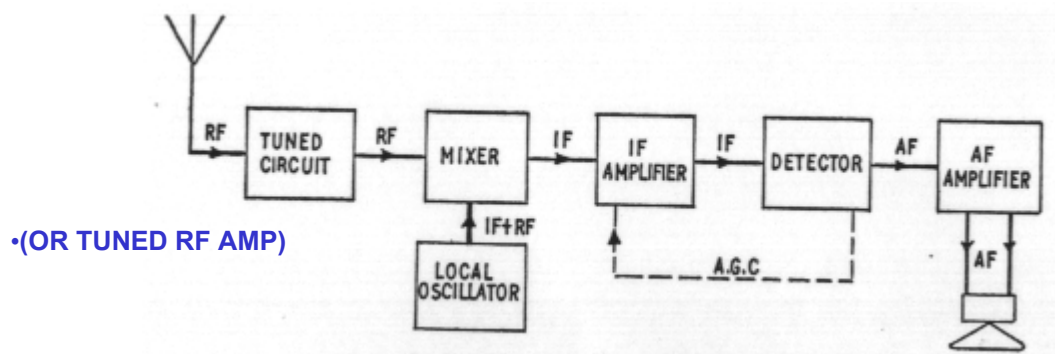

- **Example:** RF = 1800 ~ 2000 kHz (tunable); IF = 455 kHz.
- Tracking (ganged) RF and LO tuning.
- Alternative: RF bandpass filter (BW = tuning range for specific band).
- Local Oscillator (LO) = $RF + IF = 2255 \sim 2455$ kHz. (high-side injection).
- Alternative: $RF - IF = 1345 \sim 1545$ kHz (low-side injection).
- Bandpass IF amplifier has sufficient BW for mode in use (e.g. AM: 6 kHz).
- AGC (automatic gain control) holds output constant over wide range of RF signal strengths.

The Superheterodyne Receiver: the problem of images



- Per Slide 12, $f_1 = 2255$ kHz (LO), $f_2 = 1800$ kHz (RF); $(f_1 - f_2) = 455$ kHz (IF).
- If $f_1 = 2255$ kHz (LO), $f_2 = 2710$ kHz (RF), $(f_2 - f_1) = 455$ kHz. Thus, 2710 kHz signal will pass through the IF amplifier and be demodulated. This undesired response is termed the **image**, and is offset from the desired response by **twice the IF**.
- BW of RF amplifier with single-tuned input & output circuits is narrow enough to provide adequate image rejection at frequencies below 10 MHz. (Typical BW = 300 kHz at -3 dB).
- Above 10 MHz, cascaded RF amplifiers with 3 or more tuned circuits are required for acceptable image rejection. Higher IF also improves image rejection, but narrow IF BW is more difficult to obtain at higher freq.
- RF tuned circuits with narrower BW have higher **insertion loss**. This degrades sensitivity. Cascaded RF amplifiers offset this loss, but are more prone to **overload**.

The Superheterodyne Receiver: the problem of images

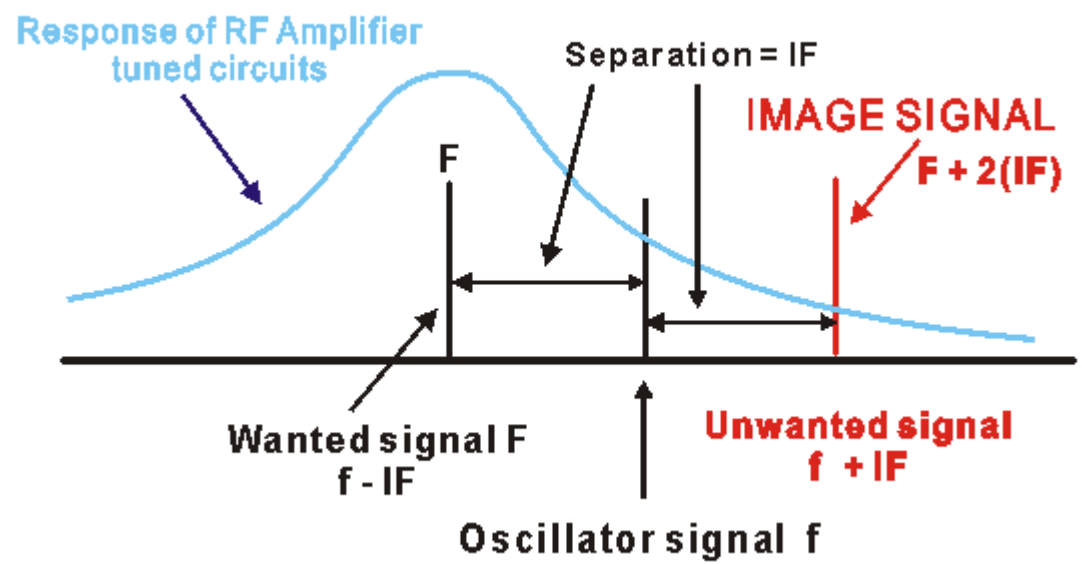

Note on Noise Figure



- **Note** on the noise factor (and noise figure) of a chain of two-port networks: The noise factor **F** of a two-port network is defined as the ratio of the signal-to-noise ratios at the input and output ports. $F = (S/N_{in}) / (S/N_{out})$ {*F expressed as a ratio*}
- Noise figure **NF** = $10 \log_{10} F$ dB
- Given three such networks in cascade, where **F₁**, **F₂**, **F₃** are the respective noise factors (*expressed as ratios*) and **G₁**, **G₂** are the respective stage gains (*also expressed as ratios*):
 - ◆ System noise factor $F_s = F_1 + [(F_2 - 1) / G_1] + [(F_3 - 1) / G_1 G_2]$ etc.
 - ◆ System noise figure $NF_s = 10 \log_{10} F_s$ dB as before.
- It will thus be seen that the noise figure of the first stage following the RF input *dominates the system noise figure*, provided that this stage has significant gain. If the first stage has insertion loss (e.g. a passive BPF or preselector), the system noise figure will be degraded by the amount of this loss.
- Proper gain/loss distribution in a receiver front end requires that the gain of the RF amplifier ("preamp") be more than sufficient to overcome the insertion loss of the preceding BPF, and that the noise figure of the RF amplifier/BPF be lower than that of the first mixer.